



A Selection of Drill Rigs using Overall Equipment Efficiency Approach

^aGeorge Agyei, ^bIsaac Asamoah

^aDepartment of Mining Engineering, University of Mines and Technology, Tarkwa, Ghana

^bAsanko Gold Mine Ltd., Ashanti Region, Ghana

ARTICLE INFORMATION

Article history:

Received 15 April 2019

Revised 24 April 2019

Accepted 26 April 2019

Available online 13 June 2019

Keywords: OEE, Drill Rig,
Penetration Rate, Availability,
Utilisation, Mining Equipment

ABSTRACT

This paper examines the utilisation, availability and penetration rates of percussive Pantera drill rig fleet used in lower saprolite and the fresh ore profiles at Nkran Pit of Asanko Gold, Ghana. The adapted application of Overall Equipment Effectiveness (OEE) in drill rigs for the determination of penetration rates for mining operations is done. For the measurement of overall equipment effectiveness, it is necessary to determine the magnitude of the types of production losses in order to plan activities and allocate resources effectively. The availability and utilisation data from the field were analysed using graphical and analytical methods. The data collected on the projected annual metres as well as the rock characteristics of the various rock formations helped improve the planning of drilling operations. Analysis of the information from analytical and graphical sources suggested that the Pantera drill rigs were more productive in the transition zone. It was also determined that a total of five (5) active Pantera drill rigs would be required by the open pit mine to meet the projected annual metres of 543 027 m. The results obtained may serve as guide for the determination production indices of drill rigs in similar geologic formations for an effective mine planning.

1. Introduction

Overall Equipment Effectiveness (OEE) is elaborated in [1] to evaluate how equipment is utilized. OEE is an indicator of how well the equipment works as compared to its potentialities. The combination of OEE and Total Productive Maintenance (TPM) provide a good indicator that can lead to performance management priorities. OEE can be an important performance indicator for drilling machines, however the application of this concept for drill rigs for mining applications is scanty. [1] expresses OEE as a function of availability, performance and quality rates shown in Eq.(1). This concept reveals six main losses for computing availability performance and quality. The operating time is also negatively affected by downtime, speed and quality losses which are further divided on the basis of their concrete reasons. Fig.1 depicts that any time component of the operating system is affected by three losses like downtime, speed and quality losses.

In Fig. 2, [2] proposes that the equipment must work for a full calendar year. The constituents of [2] model are shown in Fig. 2. The distinctive features between Jeong and Phillips and Nakajima are as follows: Jeong and Phillips model is based on full calendar year whilst Nakajima considers active time of the equipment for evaluating the OEE.

Due to the distinctive approaches between these models, it is important to define the method of analysis clearly before the evaluation of production systems. Active time approach gives higher values for OEE index as compared to the calendar time models.

Conceptualised applications of OEE for drilling machines are found in [3]. For other mine machinery, [4] applies OEE components for evaluating the performance of Bucket based Excavating, Loading and Transport (BELT) equipment. A plethora of publications shows the applicability of OEE in manufacturing industries [5]; [6]; [7]; [8]. Maintenance methodologies have been put in place to improve truck availability and utilisation in open pit mines [9]; [10]. However, limited attention is given to the impacts of drill rigs availability and utilisation on mine production [3]. Given the holistic approach of the OEE and its practical applications, the aim of this research is to translate the concept of OEE for MMU's equipment by introducing the appropriate methodologies and tools for measurement of OEE in MMU's in large scale mining operations. Therefore, the objective of this work is to translate the OEE for drilling equipment by evolving appropriate methodologies and tools for measurement of penetration rates to estimate the performance of drilling to determine the number of drill rigs needed to match the projected annual meters at Nkran Pit of Asanco Mine, Ghana.

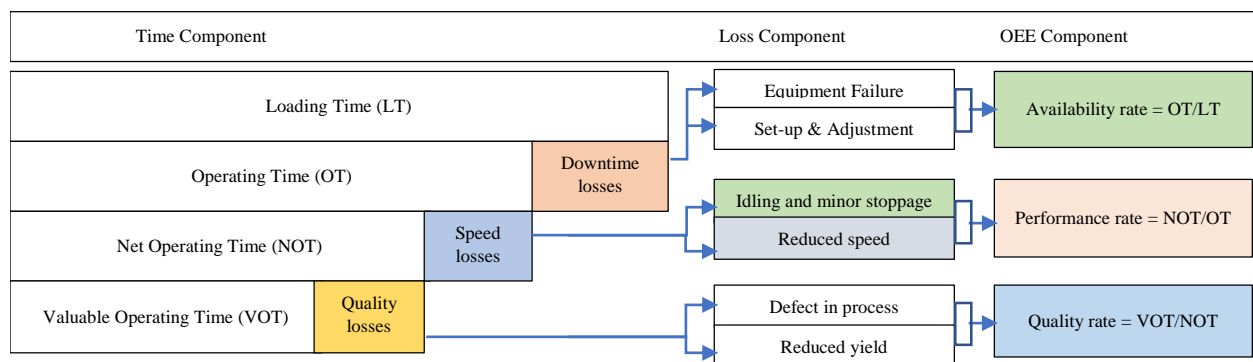

Fig.1 The Components of OEE based on Nakajima's Proposition [1]

The proposal of Nakajima defines OEE as directly proportional to availability, performance and quality rates as expressed in Eq. (1).

$$QEE = \text{Availability} \times \text{Performance rate} \times \text{Quality} \quad (1)$$

Deductions from

Fig.1 shows that OEE can be expressed as in Eq. (2) as follows;

$$OEE = \frac{VOT}{LT} \quad (2)$$

[2] considers the calculation of OEE using the calendar time in contrast to Nakajima's method which is centered on the loading time. The factors considered for the calculation of OEE using [2] are shown in Fig. 2.

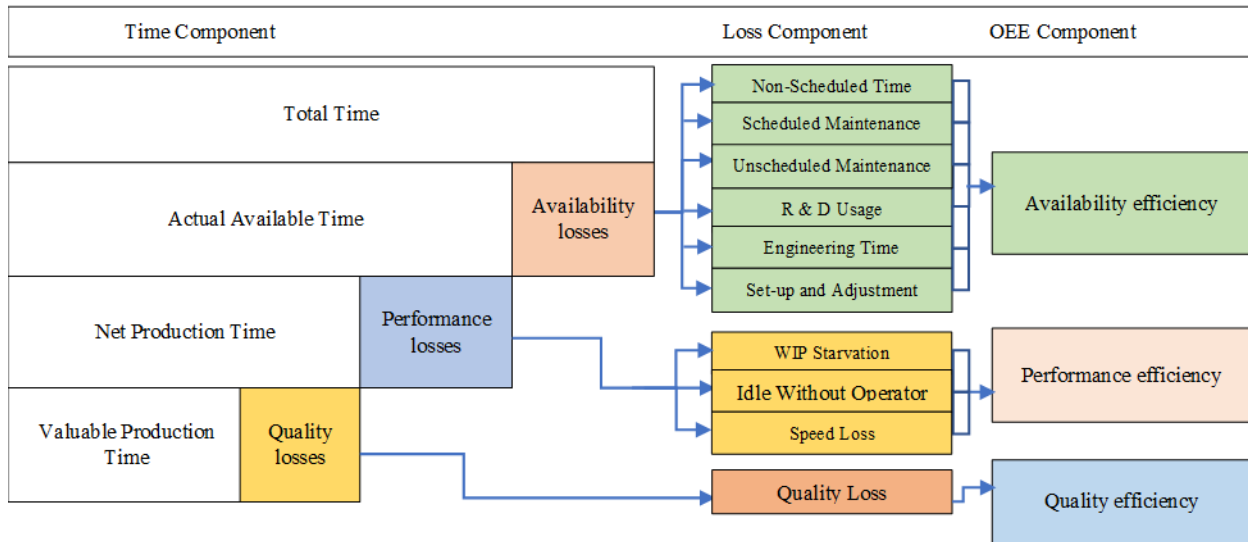

Fig. 2. The OEE factors [2]

$$OEE = \frac{\text{Valuable Production Time}}{\text{Total Calendar Time}} \quad (3)$$

However, drill rigs in the mining industry have very limited adoption of OEE as a good performance indicator. The concept of OEE and its application has not been fully realised in the use of drilling in the mining industry.

Drilling is the initial step in hard rock open-pit mining. It goes hand-in-hand with the blasting operation to ensure sufficient fragments for the excavation employed [11]. Drilling is required for a variety of mining or mining-related activities including production, ground support installation, hydrological studies, dewatering, and exploration and geotechnical investigations [12].

Penetration rate is the most important parameter for drilling performance optimisation [13]. Penetration rate is the depth of penetration achieved per unit of time with a given type of rock, drill, bit diameter and air or water pressure (m/hr.). Penetration rate (PR) is expressed in Eq. (4) as:

$$PR = \frac{L}{T} \quad (4)$$

Penetration rate is a function of the impact energy imparted to the bit, frequency of impacts, feed pressure, rotational speed, drill bit type, and rock mass properties. A typical drill unit is capable of delivering 10 to 25 kW of energy to the drill string with an impact frequency between 20 Hz and 70 Hz (impacts per second). The drill rotational speed ranges from 0 to about 100 rpm, with the maximum for a given drillhole size defined by an angular speed at the bit perimeter of approximately 0.4 m/s. Depending on the rock mass properties, penetration rates of 0.5 – 2.5 m/min can be achieved. [10] , defines availability as the probability that a piece of equipment is functioning satisfactorily at a specified time, when used according to specified conditions, where the total time includes operating time, logistical time, active repair time, and administrative time. Therefore, the equipment availability is the proportion of time the equipment is able to be used for its intended purpose. Availability reflects the part of the scheduled hours that the machine is mechanically and electrically ready to be operated.

Availability is expressed in Eq. (5) as [14]:

$$A = \frac{SSH - (MH + BH)}{SSH} \quad (5)$$

The scheduled shift hours (SSH) is the total time available for the operation of the drill rig during a shift. Such time excludes break times, change over times, safety/production meeting times and other delays within the shift.

Maintenance hours (MH) represent the hours the drill rig is not available due to planned/preventive maintenance schedule of the machine. This is also known as planned downtime.

Breakdown hours (BH) represent the time that the drill rig is being repaired due to unscheduled breakdowns. This may also be referred to as unplanned downtime.

Utilisation is the operational availability to the fraction of the available time that the drill rig is actually operated. It is also referred to as the percentage or fraction of the scheduled shift hours (SSH) that the machine does productive work. Events that may lead to the non-utilisation of the machine include dozer works, delays in marking up and operator convenience time. Other factors that may affect the utilisation of the rigs include competency of mine personnel, efficiency of mine plan and support equipment commitment [14].

Utilisation is expressed in Eq. (6) as [15]:

$$U = \frac{SSH - (MH + BH + IH)}{SSH} \quad (6)$$

Idle hours (IH) represent the hours that the machine is mechanically and electrically ready to be operated but is not utilised due to some of the factors listed earlier on.

The Nkran deposit is located within the Asankragwa gold belt, which is hosted along the axis of the North East-striking Kumasi Basin, a meta-sedimentary group forming the upper portion of the Birimian volcano-sedimentary sequence (supergene) group [16].

2. Methodology

To achieve the objective, the following methods were employed:

- (i) Field visit and data collection; and
- (ii) Graphical and statistical analysis of data.

The research was conducted at Nkran Pit of Asanko Gold Ghana Limited (Nkran pit) to examine the performance of Pantera drill rigs on the various rock formations for the determination the number of drill rigs needed to match the planned production.

The penetration rates of nine (9) Pantera drill rigs were determined in a systematic manner. During the data collection, the daily drilling report per rig was taken into consideration. The daily distance drilled and productive time per rig were considered for a period of eight (8) working days both in the fresh and the transition zones. The projected penetration rate for the Sandvick Pantera drill rigs at Asanko Gold Ghana Limited is 26 m/hr.

The determination of the Number of Pantera Drill Rig (ND) to match the Projected Annual Meters (PAM) was done using the following: Scheduled Time per Day (STD), Effective Working Regime per Day (EWD), Meters Drilled per Day (MDD), Meters Drilled per Year (MDY), Number of Drill Rigs (ND)

Scheduled Time per Day (STD) was determined using Eq. (7).

$$STD = STF \times NSD, \text{ hours} \quad (7)$$

Effective Working Regime per Day was calculated using Eq. (8) as:

$$EWD = STD \times A \times U \quad (8)$$

For a particular drill rig; Meters Drilled per Day was determined using Eq. 9 as

$$MDD = PR \times EWD \quad (9)$$

The calculation of meters drilled by year was done using Eq. (9) as:

$$MDY = MDD \times WY \quad (10)$$

Number of drill rigs required was projected using Eq. (10).

$$ND = \frac{TAM}{MDR} \quad (11)$$

The mythologies used in [3] and [4] were considered in the elaboration of the procedures for this work. [3] discusses availability and utilisation of drill rigs and their impacts on output in surface mine whilst [4] translates the concepts of OEE to Bucket based Excavation Loading and Transport Equipment (BELT).

3. Results and Discussion

3.1 Rock Properties

The physical and mechanical properties of the massive rock intended for drilling have significant effects on the penetration rate, bit wear and overall drilling costs. Hence, the appraisal and understanding of the rock formation and its characteristics contribute to the comprehensive analysis of the performance of the drill rig. However, the strength of the rock (uniaxial compressive strength) has an appreciable influence on drilling force required and the penetration rate. Table 1 presents summary of uniaxial compressive strength and specific gravity of the various rock formations at Nkran pit.

Table 1: Summary of Rock Properties at Nkran Pit, AGGL

Rock Formation	Uniaxial Compressive Strength (MPa)	Specific Gravity (g/cm^3)
Oxide	-	1.7
Transition	35	2.3
Fresh	75	2.7

3.2 Penetration Rate of the Pantera Drill Rigs in the Transition Zone

In order to determine the penetration rate of the various Pantera drill rigs, the productive time and the length drilled per drill rig for a period of eight (8) working days at Nkran West (lower saprolite or transition zone) were taken. The results are shown in Table 2.

Table 2: Penetration Rate of the Various Pantera Drill Rigs in the Transition Zone

Drill Rig ID	Productive Hours (hr)	Meters Drilled (m)	Penetration Rate (m/hr)
HDR19	95.99	2303.20	23.99
HDR22	113.00	2892.00	25.59
HDR23	112.00	2612.50	23.33
HDR24	135.00	3472.50	25.72
HDR25	110.00	2744.00	24.95
HDR26	34.00	737.60	21.69
HDR27	114.00	3242.30	28.44
HDR28	136.00	4394.70	32.31
HDR29	106.00	3158.40	29.80
Average Penetration Rate (m/hr.)			26.20

3.3 Analysis of the Penetration Rate of the Pantera Drill Rigs in the Transition Zone

Fig.3 illustrates the penetration rates of nine (9) Pantera drill rigs used for the analysis at the lower saprolite zone (transition zone) at Asanko Gold Mine Ghana Limited, Nkran Pit.

From Fig 3, HDR27, HDR28 and HDR29 exceeded the projected penetration rate of 26 m/hr. whilst the penetration rates of the remaining rigs HDR19, HDR22, HDR23, HDR24, HDR25, and HDR26 fell below the projected penetration rate of 26 m/hr. HDR27, HDR28 and HDR29 are new versions of Sandvick DP 1500i Pantera drill rigs with high impact rate whilst the remaining drill rigs are old versions with relatively low impact rate. The new versions have an average impact rate of 3.80 m/min and the old versions have an impact rate of 3.06 m/min in the transition zone which probably accounted for the differences in the penetration rates.

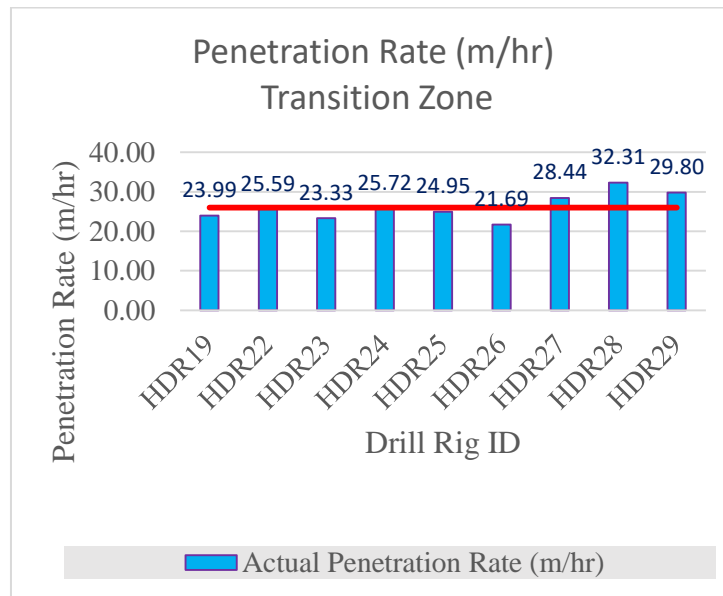

Fig. 3 Graph of Penetration Rate versus Drill Rig ID in the Transition Zone

Penetration Rate of the Pantera Drill Rigs in the Fresh Zone

To determine the penetration rates of the various Pantera drill rigs at fresh zone, the productive time and the length drilled per drill rig for a period of eight (8) working days at Nkran East (fresh zone) were measured. The results are shown in Table 3.

Table 3: Penetration Rate of Various Pantera Drill Rigs in the Fresh Zone

Drill Rig ID	Productive Hours (hr.)	Meters Drilled (m)	Penetration Rate (m/hr.)
HDR19	86.00	1874.70	21.80
HDR22	140.00	3338.40	23.85
HDR23	135.00	3088.10	22.87
HDR24	137.00	3050.80	22.27
HDR25	102.00	2326.10	22.80
HDR26	60.90	1288.10	21.15
HDR27	132.00	3670.10	27.80
HDR28	103.00	3102.00	30.12
HDR29	133.00	3882.20	29.19
Average Penetration Rate (m/hr.)			24.65

3.4 Analysis of the Penetration Rate of the Pantera Drill Rigs in the Fresh Zone

Fig. 4 illustrates the penetration rate versus the drill rig ID of the various Pantera drill rigs whose performance were assessed at Nkran East (Fresh zone).

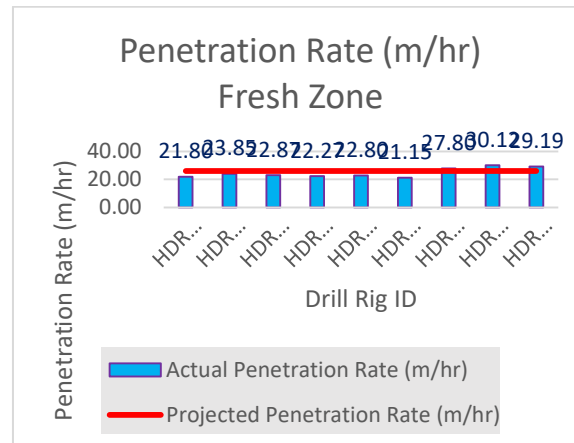

Fig. 4: Graph of Penetration Rate versus Drill Rig ID in the Fresh Zone

From Fig.4, HDR27, HDR28 and HDR29 outstripped the projected penetration rate of 26 m/hr. whilst the remaining rigs have their penetration rate below the projected penetration rate of 26 m/hr. The new versions i.e. HDR27, HDR28 and HDR29 have relatively higher frequency rock drills which deliver more impacts at a rate of 3.87 m/min with greater power whilst the old versions have relatively low frequency rock drills which deliver less impacts at a rate of 3.38 m/min with less power accounting for the differences in the penetration rates of the Pantera drill rigs in the fresh zone.

3.5 Determination of the Number of Pantera Drill Rig to match the Projected Annual Meters

Based on Nakajima's proposition, the overall equipment effectiveness of drill rig has been transcribed and defined as a product of availability, utilisation, speed factors and operational factors. Fig.5 shows that OEE and all the losses associated to time, speed, drill utilisation deployed in the open pit. Operating factors include parameters related to the components of the drilling unit, drill rod, bit, and the nature of the circulating fluid. These variables are considered together with the specific environmental conditions. Other key variables intimately related to the operating factors are drill power, axial thrust, torque, blow energy, blow frequency and rotary drill speed. Drillability is associated with opposition of the rock to penetration of a drilling instrument (Kramadibrata *et al.*, 2001). Therefore, the application of tensional force beyond the compressive strength of the rock will cause the rock to disintegrate.

Drill Performance is related the following:

- i. The cost of drilling per meter of drillhole;
- ii. The ratio of the total maintenance cost per year to the meter drilled per year;
- iii. Ratio of breakdown hours to operation hours;
- iv. Availability; and
- v. Utilisation.

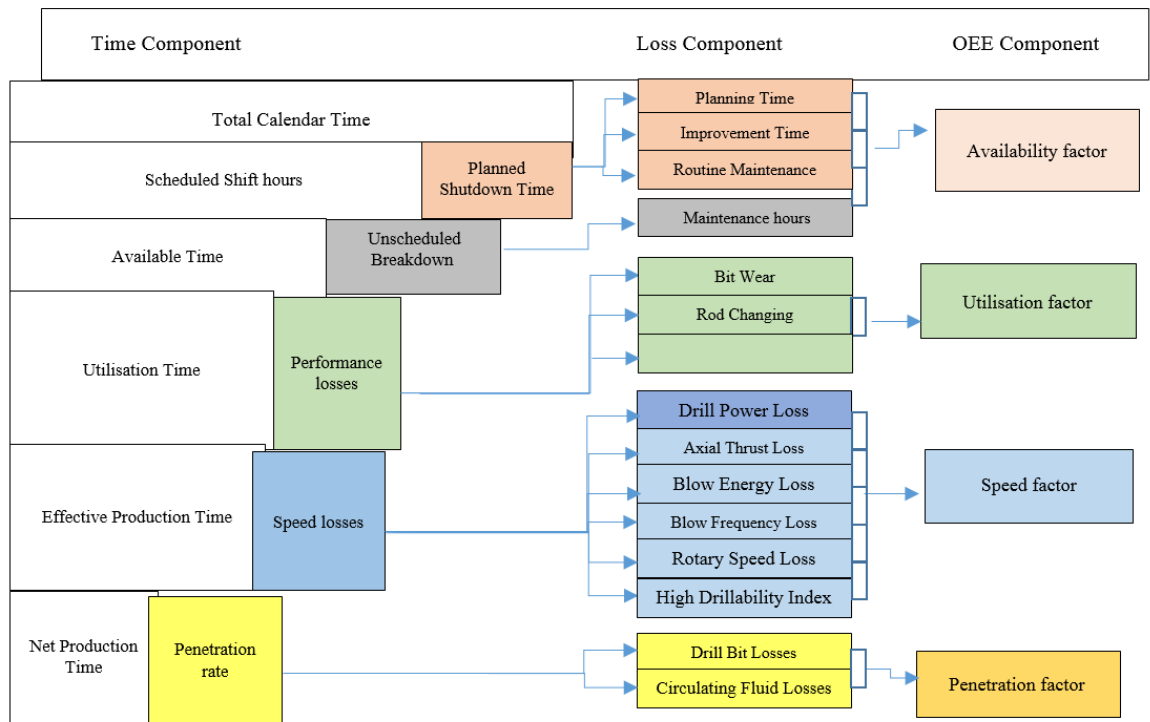

Fig. 5 OEE components of drill rig equipment

Availability factor is related to the operation of the rig. It can be denoted as (A). Utilization means the effective use of the equipment in available hours. It can be expressed as (U). Speed factor explains the rate of planned productive time and the actual productive time of the rig. Penetration factor (P) is associated with the productive use of the working organ of the drill taking into consideration the actual penetration rate and the projected penetration. The penetration factor is intimately dependent on parameters of the drill bit and the circulating fluid. Consequently the mathematical relationship is expressed in Eq. (11).

$$OEE = A \times U \times S \times D \tag{11}$$

Given the projected annual drilled length of 543 027 m , it is vital to determine the total number of Pantera drill rigs that can accurately match the projected annual drilled length such that the overall drilling cost can be minimised. Tables 4 provides the essential data required to clearly determine the total number of Pantera drill rigs needed.

Table 4: Requirements for Determining the Number of Pantera Drill Rigs

Parameters	Rock Formation		Average
	Transitional Zone	Fresh Zone	
Actual Availability (%)	90.56	88.89	89.73
Actual Utilisation (%)	63.26	67.83	65.55
Actual Penetration Rate (m/hr.)	26.20	24.65	25.43

From Table 4:

Actual Penetration Rate	= 25.43 m/hr.
Actual Availability	= 89.73 %
Actual Utilisation	= 65.55 %

Other parameters:

Projected Annual Meters	= 543 027 m
Scheduled Work Hours per Shift	= 10.5 hrs.
Number of Shifts per Day	= 2
Working Regime per Year	= 365

The values were substituted in Eq.s (7) to (11) and the results are as follows:

Drill rigs (ND)

Scheduled Time per Day (STD)

$$\begin{aligned} \text{STD} &= \text{STF} \times \text{NSD}, \text{ hours} \\ &= 10.5 \times 2 \\ &= 21 \text{ hrs.} \end{aligned}$$

From Effective Working Regime per Day

$$\begin{aligned} \text{EWD} &= \text{STD} \times \text{A} \times \text{U} \\ &= 21 \times 0.8973 \times 0.6555 \\ &= 12.35 \text{ hrs.} \end{aligned}$$

For a particular Pantera drill rig; Meters Drilled per Day

$$\begin{aligned} \text{MDD} &= \text{P R} \times \text{E W D} \\ &= 25.43 \times 12.35 \\ &= 314.06 \text{ m} \end{aligned}$$

$$\text{MDY} = \text{M DD} \times \text{W Y}$$

$$\begin{aligned} &= 314.06 \times 365 \\ &= 114\,631.90 \text{ m} \end{aligned}$$

Number of drill rigs required.

$$\text{ND} = \frac{\text{TAM}}{\text{MDR}}$$

$$\begin{aligned} \text{Number of Drill Rigs Required} &= \frac{\text{Total Annual Meters}}{\text{Meters Drilled per Rig}} \\ &= \frac{543027}{114631.90} \\ &= 4.74 \\ &\cong 5 \text{ Rigs} \end{aligned}$$

Hence a total of five (5) Pantera drill rigs and one (1) reserve drill rig are required to match the projected annual meters of 543 027 m production plan. Further study should be conducted on the operator efficiency and skills on the Pantera drill rigs to assess their impact on the projected annual meters. Measures should be put in place to ensure that the actual utilisation of the Pantera

drill rigs conforms to the AGGL's projected utilisation of 85%. This technical assessment would contribute to the methodology for the determination of production rigs fleets and the selection of drills for similar geologic formation to ensure and efficient mine planning.

4. Conclusion

The application of Overall Equipment Efficiency for drill rigs with the use of appropriate methodologies and tools for measurement of penetration rates to estimate the performance of drilling to determine the number of drill rigs needed to match the projected annual meters at Nkran Pit of Asanco Mine in Ghana was done.

Penetration rates in the transition and fresh zone and estimation of the performance of drill rig for the calculation of the number of drill rigs that could be matched with the projected annual meters have been determined. The average penetration rates are 26.20 m/hr. and 24.65 m/hr. in the transition and fresh zone respectively. This might be attributed to the differences in the uniaxial compressive strength of the various rock formations. A total of five (5) Pantera drill rigs would be required to meet the projected annual meters of 543 027 m.

Nomenclature

L	Length of Drill Hole
T	Blast Hole Drilling Hours
A	Equipment Availability
SSH	Scheduled Shift Hours
MH	Maintenance Hours
U	Drill Rig Utilization
IH	Idle Hour
STF	Scheduled Work Time per Shift,
NSD	Number of Shifts per Day
A,	Actual Availability
U	Actual Utilisation
STD	Scheduled Time per Day
PR	Actual Penetration Rate
WY.	Working Regime of the Year
TAM	Total Annual Meters
MDR	Meters Drilled per Rig

References

- [1] S. Nakajima (1988). Introduction to TPM- total productive maintenance. Productivity, Cambridge Press,
- [2] K.Y. Jeong and D.T. Phillips (2001). Operational Efficiency and Effectiveness Measurement, *IJOPM*, Vol.21, No. 11, pp. 1404-1416.
- [3] B.A. Kansake and R.S. Suglo (2015). Impact of availability and utilisation of drill on production at Kanjorle Minerals Limited. *International Journal of Science, Environment and Technology*, Vol.4, No.6, pp. 1524-1537.
- [4] M. Mohammadi, P. Rai, S. Gupta 2017. Performance evaluation of Bucket based Excavating, Loading and Transport Equipment. *Arch. Min. Sci.* 62, 1, pp. 105-120.
- [5] P.H. Tsarouhas 2013.Evaluation of overall Equipment effectiveness in the beverage industry. *IJPR* 51, 2, pp. 515-523.
- [6] S. Zendied, S.A.N Nilipour, M. Ghandehary (2012) Evaluation of overall equipment effectiveness in a continuous process production system of condensate stabilisation plant in Assaloyeh. *IJCRB* 3, 10, pp. 590-598.
- [7] F. Anvari, R. Edwards A. Starr (2010).Methodology and theory evaluation of overall equipment effectiveness based on market. *JQME*, 16(3), 256-270.
- [8] H. Wibowo (2012). Analysis of Overall Equipment Effectiveness in improving productivity in the machine processing creeper hammer mill crumb rubber. *IJES* 3, 2, pp. 52-60.
- [9] S. Elevli and B. Elevli (2010).Performance Measurement of Mining Equipment by Utilizing OEE. *Acta Montanistica Slovaca Rocnik*, 15(2,) 2010, pp. 95-101.
- [10] B.S. Dhilton (2008). *Mining Equipment Reliability, Maintainability and Safety*. Springer. Verlag, London, pp 209.
- [11] B. Chitwood and N.E Norman (1977). Blasthole Drilling Economics a Look at the Costs behind the Costs. *Engr. and Min. J*, pp.300 – 301.
- [12] J. Rostami and D.F Hambley (2011). Blasthole Drilling, *In* Darling. P. (ed.) Chap. 7.2 of *SME Mining Engineering Handbook*. 3rd Edition, Vol. 1, Society for Mining, Metallurgy, and Exploration, Inc., pp. 435 – 441.
- [13] S.A. Aalizad (2011). Prediction Penetration of Rotary-Percussive Drilling using Artificial Neural Networks. A Case Study Sangan Iron mine Project (SIMP), Unpublished MSc Thesis, Islamic Azad University. Science and Research Branch. Tehran, Iran. 179 pp.
- [14] V.A. Temeng (2015) *Surface Mining Systems*. Unpublished BSc. Lecture Notes University of Mines and Technology. Tarkwa. .
- [15] P. Rai (2004). Performance Assessment of Draglines in Opencast Mines. *Indian J. of Engr.and Mat. Sci.* Vol. 11: 493 – 498.
- [16] D James (2014). Nkran 3D Geological Model and Constraints on Mineralisation. *Asanko Gold Inc. PMI Gold Corp.* Asanko Gold Ghana Limited, Ghana
- [17] S. Kramadibrata, A.R. Made, J. Juanda, G.M. Simangunsong, N. Priagung (2001). The use of dimensional analysis to analyse the relationship between penetration rate of Jack Hammer and rock properties and operational characteristics *Proceedings of Indonesian Mining Conference and Exhibition, Jakarta, Indonesia*, pp. 7 – 8.