



## Design and Fabrication of an Automatic Suspended Single Sliding Door

Osaretin Osaro and Sufianu A. Aliu\*

Department of Mechanical Engineering, University of Benin, Benin City, Nigeria

\*Email: [sufianu.aliu@uniben.edu](mailto:sufianu.aliu@uniben.edu)

### ARTICLE INFORMATION

### ABSTRACT

#### Article history:

Received 04 Feb 2021

Revised 018 Feb 2021

Accepted 09 March 2021

Available online 31 May 2021

#### Keywords:

Sliding door, automation, design and fabrication



<https://doi.org/10.37933/nipes.a/3.2.2021.5>

<https://nipesjournals.org.ng>

© 2021 NIPES Pub. All rights reserved

An automatic suspended single sliding door was designed and fabricated using materials sourced locally. The use of an automatic door can be made to solve most of the challenges associated with manually operated doors. The sliding door was tested after fabrication. The system was certified to have functioned properly as desired. The design values of the parameters were compared with the actual values measured from the system while in operation. The percentage deviation of the actual values from the design values of parameters like door opening time, door delay time, door maximum velocity, door minimum velocity, and the total time taken for the door to complete one operational cycle are 7.69%, 3.15%, 3.53%, 14.89%, and 6.51%. The deviations of the actual values from the design values are negligible. Thus, the design and fabrication of a functional suspended single sliding automatic door system was successfully executed.

## 1. Introduction

Fast and efficient movement of persons, goods and services are needed in modern days' work schedules. Doors are placed between these schedules and it plays an important role in making the work environment conducive. Any obstruction to effective movement is detrimental to the efficiency of the organization or industry and must be removed. The conventional manual door may be a barrier to effective movement [1]. Overtime, it has been a challenge for people living with disabilities to use doors without the help of someone. For persons in wheelchairs and other physically challenged persons, automatic doors are an immense boon, since conventional doors can be very difficult to work with [2].

Opening and closing of doors can be a boring job, especially in places that requires frequent opening of doors for visitors such as shopping malls, banks, hotels, theaters, and other commercial buildings. Hiring persons for this job also incurs more expenditures on the business or organization. Also, for the physically challenged persons, the use of manual door without the help of someone else has always been very challenging. For these reasons and others, the use of automatic door systems has become widely applicable and essential in commercial buildings.

A suspended single sliding door is an intelligent door which opens on its own by sensing or detecting the presence of a living being approaching the door and closes after a predetermined time delay if there is no person within its range. This kind of doors are also referred to as automatic doors. An automatic door is an automated movable barrier installed at the entrance of a room or building to restrict access or provide privacy. The automatic door is an electro-mechanical door [3]. Intelligent doors are doors whose components and elements communicate to each other and work in conjunction to perform a predetermined function. Intelligent doors use smart lock. A smart lock is an electromechanical lock which is designed to perform locking and unlocking operations on a door when it receives an instruction from an authorized device. This door is also designed to be sensitive to obstacles in the doorway. This is to ensure that the door doesn't close on somebody or something which happens to be on the path of the doorway. The safety of the automatic door is enhanced by this safety measure [4].

## 2.0 Materials and Methods

This entails the design process and design considerations. It contains material selection, the design of the system components and operation of the door.

### 2.1 Design Considerations

The success of a design depends on the absence of friction in the point of contact between the machine and the people. That is, if the people are made safer, more comfortable, more efficient or just plain happier by the use of the machine, then it can be said that the designer has succeeded [5]. The design consideration in this work include reliability, corrosion resistance, minimal cost, ease of operation, high efficiency, maintainability, locally available materials.

The functional requirements for the system include capability to provide airtight environment, provision of safe means of access, thermal resistance and provision of privacy. The operational requirements also include that the door should always open when a person or people are approaching, it should close at a predetermined time, it must be noise free during operation and must work perfectly under every atmospheric condition.

### 2.2 Materials

Materials for each component were selected with regards to the various requirements. The components and the materials selected are:

- i. **Chain drive:** A chain drive is a mechanical drive system used to transmit mechanical power or motion from one shaft to another. A chain is a series of links connected by pin joints. [6]. The material selected for the roller chain and sprockets is alloy steel. Alloy steel was selected as the material both for the chain and sprockets on the standpoint of wear resistance and strength.
- ii. **roller bearings:** The bearing is a machine element which support another moving machine element. It allows relative motion between the contact surfaces of the members, while carrying the load [7]. The material of the rollers selected is cast nylon. Cast nylon was selected because of its advantages which include: low rolling resistance, it generates low or no noise when in operation, and its ability to absorb shock and vibration.
- iii. **Door panel:** Glass door panel was selected because it is a good insulator, resistant to most chemicals, of considerable light weight, attractive and welcoming in appearance and has high compressive strength ( $1000\text{N/mm}^2$ )

iv. **Door frame and the structure:** The structure contains the door frame and other supports for the components of the system. The material selected for the structure and the frame is medium carbon steel because it is ductile, has high mechanical strength and wear resistance, it is cheap and can easily be welded and cheap.

v. **Track:** The track act as the runway for the bearing. The material of the track is steel. Steel was selected because of strength, ductility, corrosion resistance and durability.

vi. **Floor guides:** The floor guides prevent the swinging of the glass door while in operation. Steel was selected as the material for the floor guides because of its durability, corrosion resistance and high strength.

vii. **Electric motor:** The electric motor is used to produce or generate rotational motion which is transmitted to the glass door through the chain drive. The electric motor is a bidirectional electric motor which can rotate both in clockwise direction and counterclockwise direction. The rotation of the motor opens or closes the door in response to the signal received from the microcontroller.

viii. **Microcontroller:** The microcontroller is the central controlling unit of the whole system. It controls the rotation of the electric motor. This is achieved through the signal received by the controller from the sensor.

ix. **PIR sensors:** The PIR sensor receives the heat energy radiated by an individual moving towards the door and sends a signal to the controller. This heat energy is sensed by the sensor only when the person is within the sensor's range. The sensor's range can be adjusted to meet the need of the system.

x. **Limit switches:** Limit switches are used to automatically detect the presence of an object or monitor the movement of an object. It helps to indicate that the movement limit of the door has been reached.

xi. **Relays:** Relay is an electromechanical device that uses an electromagnet to operate a pair of movable contacts from an open position to a closed position. The advantages of relay is that it takes a relatively small amount of power to operate the relay coil. It can be used to control motors, heaters, lamp etc.

xii. **Batteries:** The battery stores DC electrical energy which can be used to power the system when there is a power outage or failure from the national grid. There are two in number. Each of the battery has a voltage rating of 6 volts. Both batteries are connected in series to supply a voltage of 12 volts.

xiii. **Timer:** The timer controls the delay time at the fully opened position before the door closes.

xiv. **Switch:** The switch is a manually operated device used to control the supply of voltage. This is achieved by making a circuit either open or closed.

xv. **Light-Emitting Diode (LED):** LED is a semiconductor light source that emits light when current flows through it. It can be used to indicate whether a circuit is closed or open.

### 2.3 Design of the System Components

The design of the system components consists of the door panel, door frame, rollers and the drive system.

### 2.3.1 The Door Panel

The door panel is the movable part of the system that slides sideways to give access to persons that want to use the door. The dimensions of the door are:

Height of the door panel (H) = 2000 mm

Width of the door panel (b) = 840 mm

Thickness of the door panel (t) = 12 mm

Mass density of the door panel material which is glass ( $\rho$ ) = 2500 kg/m<sup>3</sup>

The mass of the door can be obtained from the equation (1) [8];

$$\text{Mass of the door panel (Mg)} = \rho \times H \times b \times t \quad (1)$$

$$\text{Mass of the door panel (Mg)} = 2500 \times 2 \times 0.84 \times 0.012 = 50.4 \text{ kg}$$

$$\text{Weight of the door panel (Wg)} = (\text{Mg}) \times g = 50.4 \times 9.81 = 494.424 \text{ N} \quad (2)$$

### 2.3.2 The Door Frame

The material of the frame is medium carbon steel and its dimensions are given as Rectangular hollow section of (40×20×3) mm<sup>3</sup>.

Mass per unit length = 2.36 kg/m. [9]

$$\text{Total length of the steel material (L)} = 2H + 2b \quad (3)$$

$$= 2 \times 2000 + 2 \times 840 = 5680 \text{ mm} = 5.68 \text{ m}$$

$$\text{Total mass of the frame (Mf)} = 2.36 \times 5.68 = 13.4 \text{ kg}$$

$$\text{Weight of the frame (Wf)} = \text{Mf} \times g = 13.4 \times 9.81 = 131.5 \text{ N} \quad (4)$$

$$\text{Total weight of the door (W)} = \text{Wg} + \text{Wf} = 494.424 + 131.5 = 625.925 \text{ N} \quad (5)$$

### 2.3.3 Force Analysis for the Door

The force analysis done in the manner of [10]:

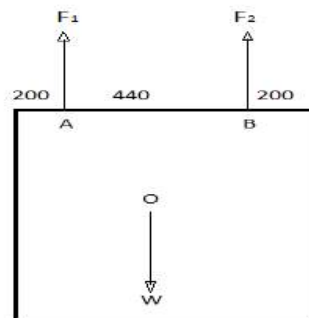

Figure 1 Free body diagram of the door

where  $W$  is the weight of the door,

$F_1$  and  $F_2$  are the forces acting on the two hinge joints.

$$\sum F_y = 0$$

$$F_1 + F_2 - W = 0$$

$$W = F_1 + F_2 \quad (7)$$

Taking moment about point A

$$\sum MA = 0$$

$$F_2 \times 440 = W \times 220$$

$$F_2 = \frac{220W}{440}$$

$$F_2 = \frac{220 \times 626}{440} = 313 \text{ N}$$

Assuming that the mass of the door is evenly distributed.

Then,  $F_1 = F_2 = 313 \text{ N}$

### 2.3.4 Selection of Roller from Manufacturer's Catalogue

Dongguan Kentie Bearing Co. catalogs and technical brochures were used for the roller selection. The process of roller selection was done following [6]. The radial load ( $F_r$ ) = 313 N, axial load ( $F_a$ ) = 0, bore diameter ( $d$ ) 10 mm (assumed), speed ( $N$ ) = 229.18 rpm, rated life of the bearing ( $L_{10h}$ ) = 60000 hours while the race-rotational factor ( $v$ ) = 1.2. The bearing is subjected to only radial load.

$$\text{Dynamic load (P)} = v \times F_r = 1.2 \times 313 = 375.6 \text{ N} \quad (8)$$

$$\text{The rating life of the bearing (L}_{10}) = \frac{60 \times N \times L_{10h}}{10^6} = 825.059 \text{ million revolutions} \quad (9)$$

$$\text{Dynamic load capacity (C)} = P(L_{10})^{1/3} = 375.6(825.059)^{1/3} = 3522.79 \quad (10)$$

From manufacturer's catalogue, for bore diameter of 10 mm; bearing number 6000 is suitable for this application. Bearing number 6000 has the specifications:

Bore diameter ( $d$ ) = 10 mm

Outer diameter ( $D$ ) = 26 mm

Axial width of the bearing ( $B$ ) = 8 mm

### 2.3.5 Force Analysis for the Rollers

Force analysis for the rollers is done in the manner of [11].

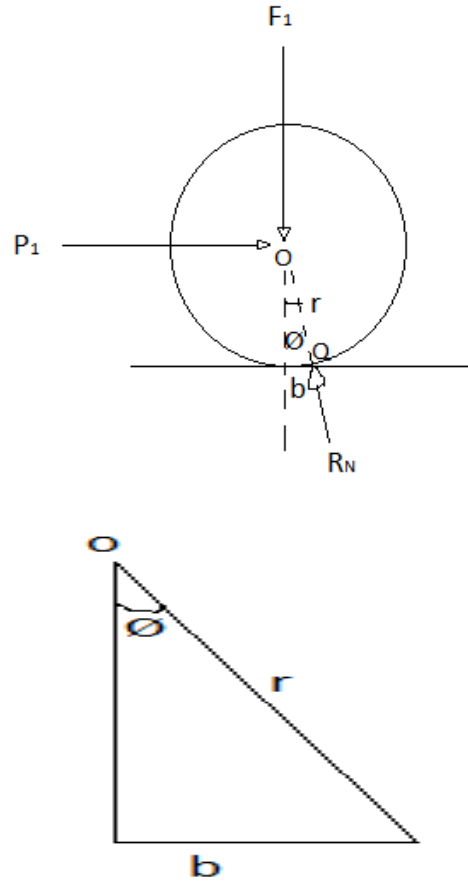

**Figure 2 Free body diagram of the roller**

where  $F_1$  is the force or load on the roller,

$P_1$  is the force required to overcome rolling resistance,  $R_N$  is the normal reaction.

$$\sum F_y = 0$$

$$R_N \times \cos(\phi) - F_1 = 0 \quad (10)$$

$$F_1 = R_N \times \cos(\phi)$$

$$\sum F_x = 0$$

$$P_1 - R_N \times \sin(\phi) = 0 \quad (11)$$

$$P_1 = R_N \times \sin(\phi)$$

$$\frac{P_1}{F_1} = \frac{R_N \times \sin(\phi)}{R_N \times \cos(\phi)}$$

$\frac{P_1}{F_1} = \tan \phi$  The value of  $\phi$  is small since the area of contact of the roller with the track is small.

Thus,

$$\tan \phi \cong \sin \phi$$

$$\sin \phi = \frac{b}{r} \quad (12)$$

From Equation (12)

$$\frac{P1}{F1} = \frac{b}{r}$$

$$P1 = F1 \times \frac{b}{r}$$

The radius of the bearing ( $r$ ) =  $\frac{D}{2} = 13$  mm

The distance ( $b$ ) is called the coefficient of rolling friction.

The value of  $b$  for cast nylon roller on steel track is 0.027 inches (0.6858 mm) [12].

$$\therefore P1 = 16.512 \text{ N}$$

The total force required to overcome rolling resistance on both rollers ( $P$ ) =  $2 P1$

$$P = 33.024 \text{ N}$$

The force ( $P$ ) is the force required to sustain its motion.

The value or magnitude of the kinetic frictional force, that acts when there is motion, is usually less than the maximum magnitude of the static frictional force that must be overcome to start motion [13].

The force ( $F_a$ ) required to start or initiate its motion is generally 2 to 2.5 times the force ( $P$ ) required to sustain its motion [12].

$$F_a = 2P = 66.048 \text{ N}$$

### 2.3.6 The Drive System (Chain Drive)

The chain and sprocket were selected from RENOLD Superior Chain Technology catalog [14].

#### i. Selection of chain

The process of chain selection was done using [6].

$$\text{Maximum velocity of the sliding door (V)} = \frac{S}{t} \quad (13)$$

Where  $S$  is the distance covered at maximum velocity,  $t$  is the time taking.

Taking  $S = 740$  mm and  $t = 4.5$  seconds

$$\text{Then, } V = 0.164 \text{ m/s}$$

The maximum velocity of the door is 0.164m/s.

The minimum velocity of the door at the extreme positions (fully closed and opening positions) is

$$(V_{min}) = \frac{S_2}{t_2}$$

where  $S_2$  is the distance covered by the door with the minimum velocity,  $t_2$  is the time taken.  $S_2 = 100$  mm (assumed),  $t_2 = 2.5$  seconds (assumed)

Minimum velocity of the door ( $V_{min}$ ) = 0.04 m/s

The total time taken for the door to get to its fully opened or closed position is the sum of the time taken during maximum velocity minimum velocity.

Total time = 4.5 + 2.5 = 7 seconds

The power required to accelerate the door =  $F_a \times V = 10.83$  W

Transmission efficiency ( $\eta_T$ ) =  $\frac{P_{out}}{P_{in}}$

$$P_{in} = \frac{P_{out}}{\eta_T} \quad (14)$$

Where  $P_{in}$  is the power input into the drive system from the motor.  $P_{out}$  is the power output from the drive system to accelerate the door. The efficiency of a well lubricated chain drive is of the range 96% to 98% [6].

Using an efficiency of 97% (assumed) and  $P_{out} = 10.83$  W

From Equation (14)

$$P_{in} = 11.165 \text{ W}$$

The input power ( $P_{in}$ ) is the power to be transmitted by the chain drive or the transmitted power (TP).

$$\text{Rating power (RP)} = \frac{TP \times K_s}{K_1 \times k_2} \quad (15)$$

Transmitted power (TP) = 11.165 W

Using a pinion (driving sprocket) with 15 teeth (assumed). For electric motor as the input power and smooth driven load, the Service factor ( $k_s$ ) is 1.0. For chain with single strand, the Multiple strand factor ( $k_1$ ) is 1.0. For pinion with 15 teeth, the Tooth correction factor ( $k_2$ ) is 0.85 [6].

$$\text{Rating power (RP)} = 13.135 \text{ W}$$

According to [6], the maximum tension in the chain drive is giving as;

$$\text{Chain tension (Pc)} = \frac{RP}{V} \quad (16)$$

$$\text{Chain tension (Pc)} = 80.09 \text{ N}$$

The driving sprocket (pinion) rotate at the same speed with the spindle of the motor.

That is, pinion speed ( $N_p$ ) = 229.18 rpm. The closest higher speed is 300 rpm [6]. At pinion speed of 300 rpm, the most suited chain drive is 06B.

Chain number 06B has a speed of 300 rpm and power rating of 0.61 kW



Chain number 06B has the dimensions and breaking load:

Pitch (p) = 9.525 mm

Roller diameter (d1) = 6.35 mm

Width (b1) = 5.72 mm

Breaking load (WB) = 8900 N

$$\text{Number of links in the chain (Ln)} = 2\left(\frac{a}{p}\right) + \left(\frac{Z_1 + Z_2}{2}\right) + \left(\frac{Z_2 - Z_1}{2\pi}\right)2 \times \left(\frac{p}{a}\right) \quad (17)$$

where Pitch (p) = 9.525 mm, number of teeth of the driving sprocket (pinion) (Z1) = 15 teeth and number of teeth of the driven sprocket (Z2) = 15 teeth

Using a center distance (a) of 1550 mm. (assumed)

Number of links in the chain (Ln) = 340.46

Since the number of links must be even, then number of links in the chain (Ln) = 340 Actual center distance (a) between the driving sprocket and the driven sprocket is given as

$$a = \frac{p}{4} \left\{ [Ln - \left(\frac{Z_1 + Z_2}{2}\right)] + \sqrt{([Ln - \left(\frac{Z_1 + Z_2}{2}\right)]^2 - 8\left[\frac{Z_2 - Z_1}{2\pi}\right]^2)} \right\} \quad (18)$$

a = 1547.8 mm

$$\text{length of the chain (L)} = Ln \times p = 3238.5 \text{ mm} \quad (19)$$

## ii. Selection of sprocket

The driving sprocket and driven sprocket have the same dimensions.

$$\text{Pitch circle diameter (D)} = \frac{p}{\sin \frac{180}{Z}} \quad (21)$$

Pitch circle diameter (D) = 45.81 mm

Top diameter (Da):

$$(\text{Da})_{\text{max}} = D + 1.25p - d1 = 51.366 \text{ mm} \quad (22)$$

$$(\text{Da})_{\text{min}} = D + p\left(1 - \frac{1.6}{Z_1}\right) - d1 = 47.969 \text{ mm} \quad (23)$$

$$\therefore \text{Top diameter (Da)} = \frac{(\text{Da})_{\text{max}} + (\text{Da})_{\text{min}}}{2} = 49.67 \text{ mm}$$

$$\text{Roller seating radius (ri)} = 0.505(d1) + 0.069(\sqrt[3]{d1}) \quad (24)$$

ri = 3.33 mm

$$\text{Root diameter (Df)} = D - 2ri \quad (25)$$

Df = 39.15 mm

$$\text{Tooth width (bf)} = 0.93(b1) \quad (26)$$

bf = 5.3 mm

### iii. Selection of electric motor

Power rating of the motor

The angular velocity of the motor ( $\omega$ ) can be obtained from Equation (27)

$$V = \omega \times r \quad (27)$$

where V is the maximum velocity of the chain, r is the pitch circular radius of the sprocket

$$\omega = 7.1616 \text{ rad/s}$$

The speed (N) required can be obtained from Equation (28).

$$\omega = \frac{2\pi N}{60} \quad (28)$$

$$N = 68.39 \text{ rpm}$$

The motor power required is the power to be transmitted by chain drive or the input power ( $P_{in}$ ) into the drive system as obtained from Equation (14).

Thus, the power rating of motor ( $P_m$ ) is 11.165 W.

The torque (T) required can be obtained from Equation (29)

$$P_m = T \times \omega \quad (29)$$

$$T = \frac{P_m}{\omega}$$

$$T = 1.56 \text{ Nm}$$

## 2.4 Duration of Operation of the Door with Battery

To ensure a continuous operation of the sliding door (whose exploded view is shown in Figure 3), when there is a power outage from the main power source, an alternative source for electric power supply has to be made through the use of batteries. A set of two batteries with voltage rating of 6v and battery capacity of 5Ah each, was selected to serve as a backup for the system. The analysis and the formulas in this section were in the manner of [15]. These batteries are connected in series.

$$\text{Total output voltage (V)} = V_1 + V_2 \quad (30)$$

where  $V_1 = V_2 = 6$  volts

The duration (Time, t) of operation of the sliding door using battery as alternative source of power supply is calculated.

$$\text{Power (P)} = IV \quad (31)$$

where V is the voltage to be supplied by the battery (12V),

P is the power required by the system (15W), I is the current.

$$I = 1.25A$$

$$\text{Battery capacity (C)} = It \quad (32)$$

where battery capacity (C) = 5Ah

$$t = 4h$$

The duration of operation of the door with battery is 4 hours.

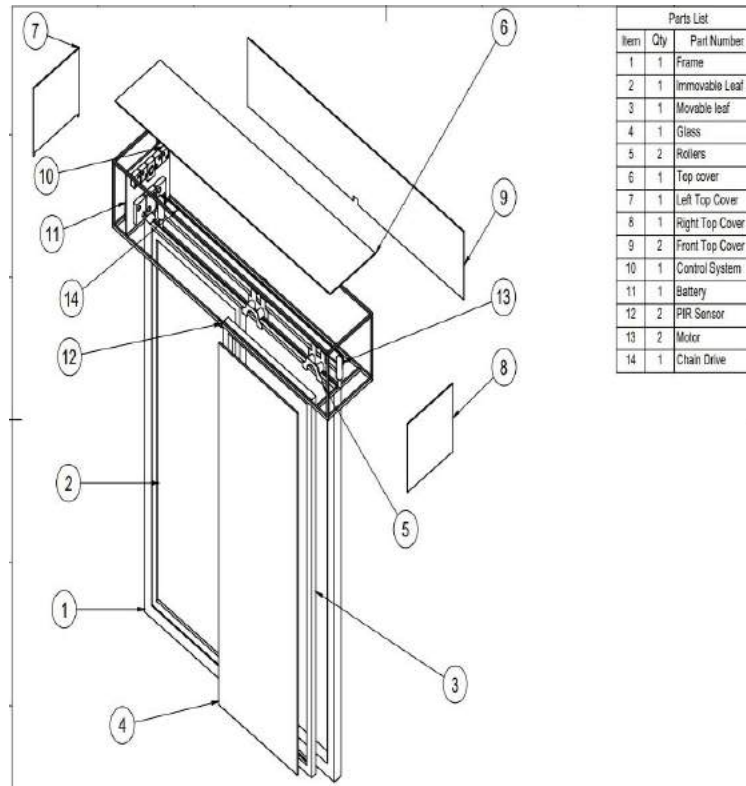

**Figure 3 Exploded view of the self-opening and closing door**

## 2.5. Operation of Sliding Door

The sliding door is an automated door system which senses the motion of a person approaching the door. The motion of the person is detected by a passive infrared sensor (PIR Sensor) mounted at the top of the door frame. The power supply circuit which converts AC to DC is connected to the PIR sensor, microcontroller, motor driver and the relay. The relay is connected to the door motor which connects to the limit switches. The limit switches are connected back to the microcontroller. The PIR sensor detects the motion of the person, within the sensor's field of view, through the thermal energy radiated from the person. The signal from the sensor is sent to the microcontroller which then initiate the rotation of the motor. The rotational motion of the motor is transmitted through the chain drive (a roller chain and two sprockets of the same specifications) to the door. This transmitted motion causes the door to slide open. The door remains opened for a predetermined period of time (4 seconds), called the delay-time, to allow the person to fully pass through the door before shutting or closing. This delay-time is adjustable.

The sliding door starts its motion with a maximum velocity and gradually come to rest with a lesser velocity. This was achieved through the use of limit switches. There are two sets of limit switches used to for this process. The first set are contact sensors (two in number) installed at both extreme of the track. The other set are proximity sensors (two in number) installed in between the two contact sensors. The proximity sensors are installed at a distance of 100mm from each of the contact sensors. When the door gets to the position of the proximity sensor, the sensor sends a signal to the microcontroller which switches the velocity of the door to a lower velocity through a set of relays. The door comes to rest slowly, when it gets to the contact sensor. The contact sensor sends signal to the microcontroller which switches the velocity of the door to zero through a relay. The door remains stationary at the fully open position for 4 seconds (which is the delay-time) to allow the person to pass through the entry way. This delay-time can be adjusted using the timer. After which, the timer sends signal to the microcontroller which changes the velocity of the door from zero to a maximum velocity through the relay. The maximum velocity of the door changes to a lower velocity on getting to the second proximity sensor at the other end of the track. Gradually, the door comes to rest at the fully closed position with the lower velocity on getting to the second contact sensor. This whole process is repeated when the PIR sensor detects the motion of a person approaching the door.

### 3.0 Results and Discussion

The farthest distance from the door at which a person's movement can be detected was 410cm. The time for door to fully open was measured (Table 1). An average value of time of 6.50secs was obtained.

**Table 1: Door Opening Time**

S/N	Door Opening Time, $t_o$ (seconds)
1	6.50
2	6.80
3	6.35
4	6.70
5	6.40
6	6.55
7	6.30
8	6.40

The closing time of the door was also measured (Table 2). The average of the recorded values was 6.27 seconds.

**Table 2: Door Closing Time**

S/N	Door Closing Time, $t_c$ (seconds)
-----	------------------------------------

1	6.41
2	6.13
3	6.30
4	6.40
5	6.25
6	6.35
7	6.20
8	6.15

The delay time which is the time spent at the door's resting position before it starts its reverse motion or movement was also measured (Table 3). The average delay time was obtained as 4.13 seconds.

**Table 3: Delay Time**

S/N	Delay Time, $t_d$ (seconds)
1	4.03
2	4.30
3	4.23
4	4.05
5	4.15
6	4.10
7	4.20
8	4.00

The actual maximum velocity obtained by measuring the time taken to cover the distance by the sliding door was obtained as 0.170m/s. the minimum velocity was also calculated from the results of tests conducted on the door. The minimum velocity was determined to be 0.47m/s.

The time taken for the door to complete its operational cycle which consists of door opening time, delay time and door closing time was obtained as 16.90seconds. The desired or design value of some of the important design parameters were compared with their actual values. The actual values were obtained from the results of testing. Table 4 shows the comparison of the values of design parameters with the actual values.

**Table 4 Deviation of the actual from design values of some design parameters**

S/N	Design Parameters	Design Value	Actual Value	Deviation	Percentage Deviation
1	Door opening time	7.00 s	6.50 s	0.5 s	7.69 %
2	Delay time	4.00 s	4.13 s	0.13 s	3.15 %
3	Maximum velocity	0.164 m/s	0.170 m/s	0.006 m/s	3.53 %
4	Minimum velocity	0.04 m/s	0.047 m/s	0.007 m/s	14.89 %
5	Total time	18.00 s	16.90 s	1.1 s	6.51 %

From Table 4, it can be seen that the deviations of the actual from the design or desired values are small. The deviations can be regarded as negligible.

#### 4.0 Conclusion

A suspended single sliding door was designed, fabricated and tested. The door can eliminate the difficulties encountered by physically challenged persons when trying to use manually operated doors, the risk of cross-contamination in places like laboratories, hospitals etc. can also be reduced by the use of the sliding door. Also, there will be no need to hire persons to be opening doors for clients in places of commerce. The ease of movement of humans and goods is enhanced. The air conditioned state of a place would be better preserved with the use of the sliding door. The system functioned properly. The percentage deviation of the actual values from the design values of the design parameters such as door opening time, door delay time, door maximum velocity, door minimum velocity, and the total time taken for the door to complete one operational cycle are 7.69%, 3.15%, 3.53%, 14.89%, and 6.51% respectively.

#### References

- [1] Chomo, D. I. G., Yawas D. S. and Johnson Z. S. (2018) "Development of Automatic Door System" American Journal of Engineering Research (AJER), Vol 7, no 5, 168-173.
- [2] Zungeru A. M., Maidawa K. D., Ambafi J. G. and Omokhafa J. T (2012). "Design and Implementation of a low cost Digital Bus Passenger Counter" Innovative Systems Design and Engineering, [www.iiste.org](http://www.iiste.org) accessed 07/01/2021
- [3] Oladumoye M., Oluwatobi A. A. and Obakin O. (2014). "Design and Construction of an Automatic Sliding Door using Infrared Sensor". Computing, Information System, Development Informatics and Allied Research Journal. Vol 5, no 4. [www.cisdijournal.net](http://www.cisdijournal.net). accessed 07/01/2021
- [4] Webster, J. G. (1999). Wiley Encyclopedia of Electrical and Electronics Engineering. (vol 4). New York: John Wiley & Sons, Inc
- [5] Dreyfuss, H. (1955) Designing for people. New York, NY: Allworth Press.
- [6] Bhandari. V.B. (2009). Design of Machine Elements. Third edition New Delhi: Tata Mc Graw Hill Education.
- [7] Khurmi, R.S. & Gupta, J.K. (2006). A Textbook of Machine Design. Multicoloured Edition. Ram Nagar, New Delhi-110055: Eurasia Publishing House Ltd., 7361
- [8] Khurmi, R. S. (2006) "Strength of Materials: Mechanics of Soilds". (1st edition), Chand (S.) & Co Ltd, India.
- [9] <https://www.ssabwebsitecdn.azureedge.net>. (10/01/2021).

- [10] Hibbeler R.C. (2010). Engineering Mechanics (Statics). Twelfth edition. ISBN-10: 0-13-607791-9.
- [11] Beer F. P., Johnson E. R, Mazurek D. F. and Eisenberg E. R. (2010). Vector Mechanics for Engineers (Statics). Ninth edition. ISBN 978-0-07-352923-3
- [12] Lippert, D and Spektor, J. (2007). Rolling Resistance and Industrial Wheels. Hamilton White Paper, No. 11
- [13] Halliday, D and Resnick, R, (2007), Fundamentals of Physics, Tenth Edition, ISBN: 978-1-118-23072-5.
- [14] RENOLD Superior Chain Technology. [www.renold.com](http://www.renold.com). accessed (17/01/2021).
- [15] Theraja, B. L and Theraja, A. K., A Textbook of Electrical Technology. S. Chand, 22nd Edition, Vol. 2, 2005.